



**ROCKMORE**  
INTERNATIONAL  
*Rock Drilling Tools*



QL8/QL80 Bit Shank  
Lower Air Consumption

**DTH HAMMER**

**ROK 875A**

Recommended Bit Diameter  
215 - 254mm [8.5" - 10.0"]



**Features:**

- Ultra High Performance Design
- Lower Air Consumption
- Higher Efficiency
- Integrated SonicFlow Technology
- Patented Innovations
- Superior Penetration Rates
- Reduced Number of Components
- Easy Assembly / Maintenance
- Advanced Materials / Heat-Treatment
- Extended Service Life

**Applications:**

- Mining / Blast Hole
- Construction / Quarry

**SonicFlow Technology** greatly improves the air flow characteristics within the ROK hammer and ensures that the high pressure air paths are optimized to deliver greater energy to the piston. This is achieved by incorporating scientific air flow concepts in the design of the hammer and its various components such as the Top Sub, Piston, and Wear Sleeve. This technology results in more impact energy to the bit and produces higher penetration rates and better overall hammer performance.



**Innovative Design Features**

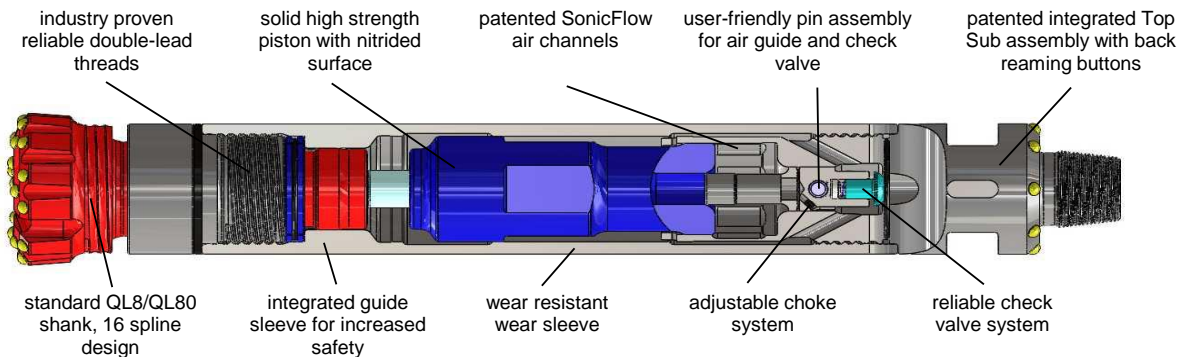

ROCKMORE International, Inc. 10065 S.W. Commerce Circle; Wilsonville, OR 97070, USA  
Tel: +1-503-682-1001; Fax: +1-503-682-1002; info@rockmore-intl.com  
ROCKMORE International GmbH Collini - Strasse 2; A-8750 Judenburg - Austria  
Tel: +43 3572 86 300-0; Fax: +43 3572 84 179; austria@rockmore-intl.at

www.rockmore-intl.com

Rev. 6-11-24



**ROCKMORE**  
INTERNATIONAL  
Rock Drilling Tools



**Integrated SonicFlow  
Technology**

# ROK 875A

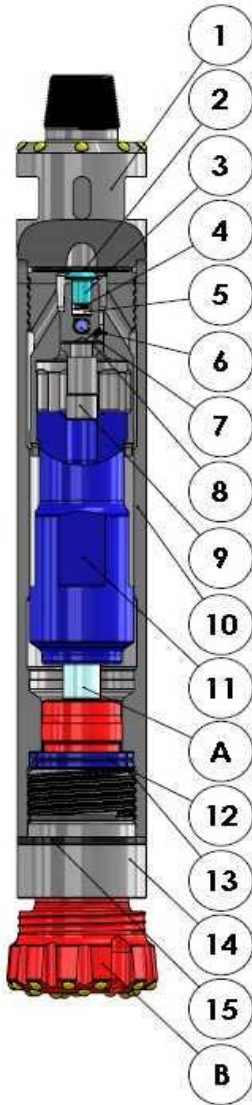

## Parts List

Item	Part Number	Description
1	ROK875A-001 875ATS-001 *	DTH Hammer, 875A, QL8/QL80, 4-1/2" API Reg Pin Top Sub, 4-1/2" API Reg Pin with Back Reaming Buttons
1	ROK875A-002 875ATS-003 *	DTH Hammer, 875A, QL8/QL80, 4-1/2" BECO Pin Top Sub, 4-1/2" BECO Pin with Back Reaming Buttons
1	ROK875A-003 875ATS-005 *	DTH Hammer, 875A, QL8/QL80, 5-1/4" BECO Pin Top Sub, 5-1/4" BECO Pin
2	R2-431	O-Ring, 5.250" X 0.250"
3	CV-003	Check Valve, Delrin
4	SP-001	Spring
5	SR-002	Spring Rest
6	CH-001	Blank Choke, Steel
7	PN-005	Pin, 1.000" Dia, 5.6" L
8	R2-226	O-Ring, 1.984" X 0.139"
9	AG-005	Air Guide - <i>includes o-ring and choke</i>
10	875AWS-001	Wear Sleeve
11	PT-023	Piston
A	BTQL8-1015	QL8/QL80 Blow Tube
12	R2-431	O-Ring, 5.250" X 0.250"
13	BR-006	Bit Retainer Ring - <i>includes o-ring</i>
14	875ADS-001	Driver Sub
15	875ABO-001	Break Out Ring
B	DTH Bit	QL8/QL80 Shank
CHSET-001		Choke Set, Steel, 1 each of CH-001 - 0" (0mm), CH-002 - 1/16" (2mm), CH-003 - 1/8" (3mm), CH-004 - 3/16" (5mm)

\* Includes o-ring

## Operating Parameters

Air Pressure	Air Consumption
10.4 Bar [150 PSI]	7.2 m <sup>3</sup> /min [256 SCFM]
17.2 Bar [250 PSI]	19.5 m <sup>3</sup> /min [689 SCFM]
24.1 Bar [350 PSI]	33.7 m <sup>3</sup> /min [1189 SCFM]
Oil consumption:	0.2 l/hr per 3.0 m <sup>3</sup> /min [1/3 pint/hr per 100 cfm]
Recommended rotation speed:	14 r/min to 50 r/min
Minimum diameter difference between wear sleeve and bit:	12 mm [0.47"]

## Technical Specifications

Bit shank type	QL8/QL80
Recommended bit diameter, mm [in]	215 to 254 [8.5 to 10.0]
Outside diameter, mm [in]	188 [7.4]
Wear sleeve discard diameter, mm [in]	175 [6.9]
Wrench flat size on Top Sub, mm [in]	124 [4.9]
Effective Length without drill bit, mm [in]	1176 [46.3] - <i>only for ROK875A-001</i>
Weight without drill bit, kg [lbs]	177 [391.0] - <i>only for ROK875A-001</i>

Patented

ROCKMORE International, Inc. 10065 S.W. Commerce Circle; Wilsonville, OR 97070, USA  
Tel: +1-503-682-1001; Fax: +1-503-682-1002; info@rockmore-intl.com

ROCKMORE International GmbH Collini - Strasse 2; A-8750 Judenburg - Austria  
Tel: +43 3572 86 300-0; Fax: +43 3572 84 179; austria@rockmore-intl.at

www.rockmore-intl.com

Rev. 6-11-24